

CASIO DIGITAL GUITAR

# DG-20

Player's Manual ...1

Manual del Ejecutante ...11

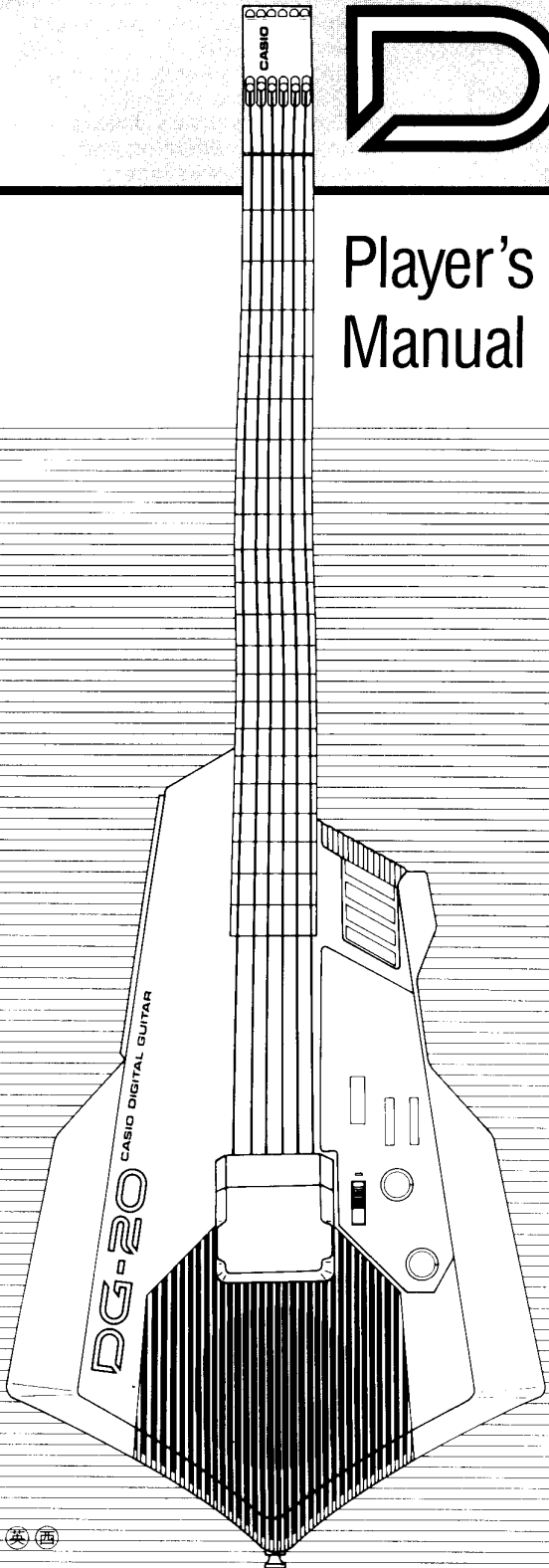

## Thank You

And congratulations on your choice of the CASIO DG-20 Digital Guitar. Your digital guitar is an entirely new type of digital musical instrument, which features the latest in state-of-the-art digital technology.

## Read the Manual

To obtain optimum performance and assure long-term reliability, be sure to read this manual carefully before playing your new DG-20 guitar.

- Contents of this manual are subject to change without notice.
- CASIO has done its best to include all pertinent information on the DG-20 in this manual. If you should find any errors or have questions on the contents, please contact your distributor.
- CASIO reserves exclusive rights to the contents of this manual.
- CASIO does not claim responsibility for damages or claims incurred as a result of the use of the DG-20 or this manual.

## Important Precautions

### ■ Please be careful of extreme temperatures, moisture and direct sunlight.

Please avoid using or storing your DG 20 in places subject to direct sunlight, excessively damp places or near air conditioning and heating appliances where temperatures and moisture tend to be extreme. Also, do not leave this unit in an automobile with the windows closed during hot summer months.

### ■ Please do not drop this instrument or subject it to strong shocks.

Subjecting this precision instrument to strong shocks may cause malfunctions or damage the neck, so please use extreme care in handling.

### ■ Make sure no foreign matter gets inside of this unit.

Please take care that no foreign objects, especially metal objects such as hair pins, sewing needles or coins get into the unit. Any metal objects or liquids entering the unit may cause malfunctioning as well as an electric shock hazard.

### ■ Customizing may cause malfunction and accidents.

The DG-20 uses many high-precision electronic components. Converting it in any manner or needlessly touching internal parts may cause malfunction and accidents and should therefore be avoided under all circumstances.

### ■ Do not use thinner or similar chemicals when cleaning this unit.

To clean the DG-20, wipe the exterior surface with a soft cloth dampened with a neutral detergent solution which has been wrung out completely. Never use paint thinner, benzene or other solvents.

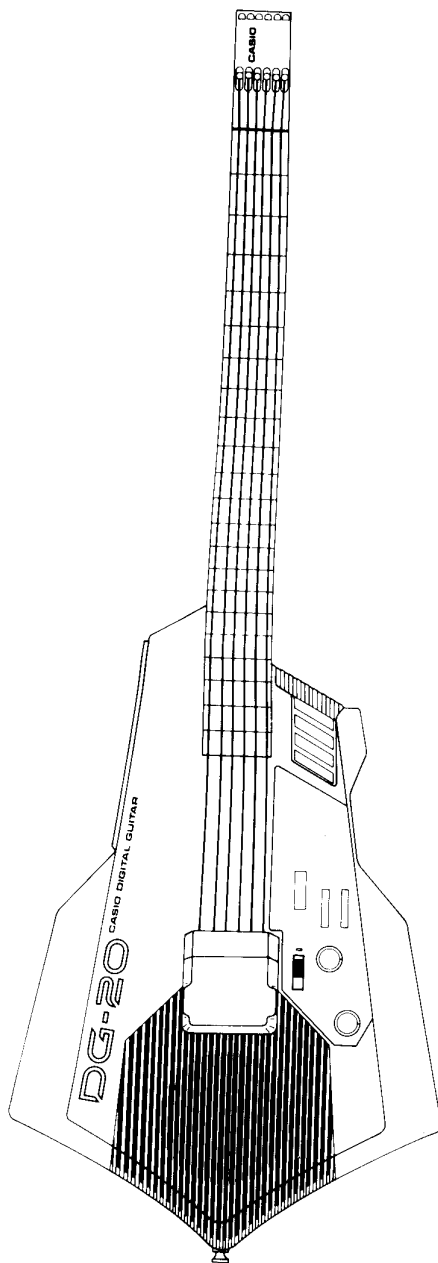

## **Contents**

<b>Features and Functions</b>	<b>3</b>
<b>Power Supply</b>	<b>6</b>
<b>Changing Strings</b>	<b>7</b>
<b>Digital Performance</b>	<b>8</b>
<b>Specifications</b>	<b>9</b>
<b>Troubleshooting Guide</b>	<b>10</b>
<b>Music Score</b>	<b>21</b>

## Overall View

- ① **Power Switch**  
Used to turn power ON and OFF.
- ② **Main Volume Control**  
Used to control volume of guitar sounds.
- ③ **Rhythm Volume Control**  
Used to control volume of rhythm sounds.
- ④ **Speaker**  
High performance 12cm (4 3/4 inch) built-in speaker.
- ⑤ **Mute Key**  
Used to mute sound during performance.
- ⑥ **Start/Stop Key**  
Used to start and stop selected auto-rhythm.
- ⑦ **Synchro/Fill-in Key**  
Used to select Synchro introduction or insert fill-ins in auto-rhythm Performance. When pressed, Tempo Indicator (⑩) flashes selected tempo. When a string is played, the auto-rhythm begins automatically, in synchronization (from 1st beat). When pressed during auto-rhythm performance, an appropriate fill-in is inserted in the rhythm pattern.  
*Press the Synchro/fill-in once more to cancel the synchro start mode.*

- ⑧ **Drum Pads**  
When these pads are tapped, corresponding drum sounds are output.

### Performances Using Auto-Rhythm and Drum Pads

When drum pads are tapped during auto-rhythm performance, the auto-rhythm automatically stops (allowing a manual fill-in). The rhythm then starts again from the beginning of the next measure. While the rhythm is stopped, the Tempo Indicator flashes out each beat, acting as a metronome.

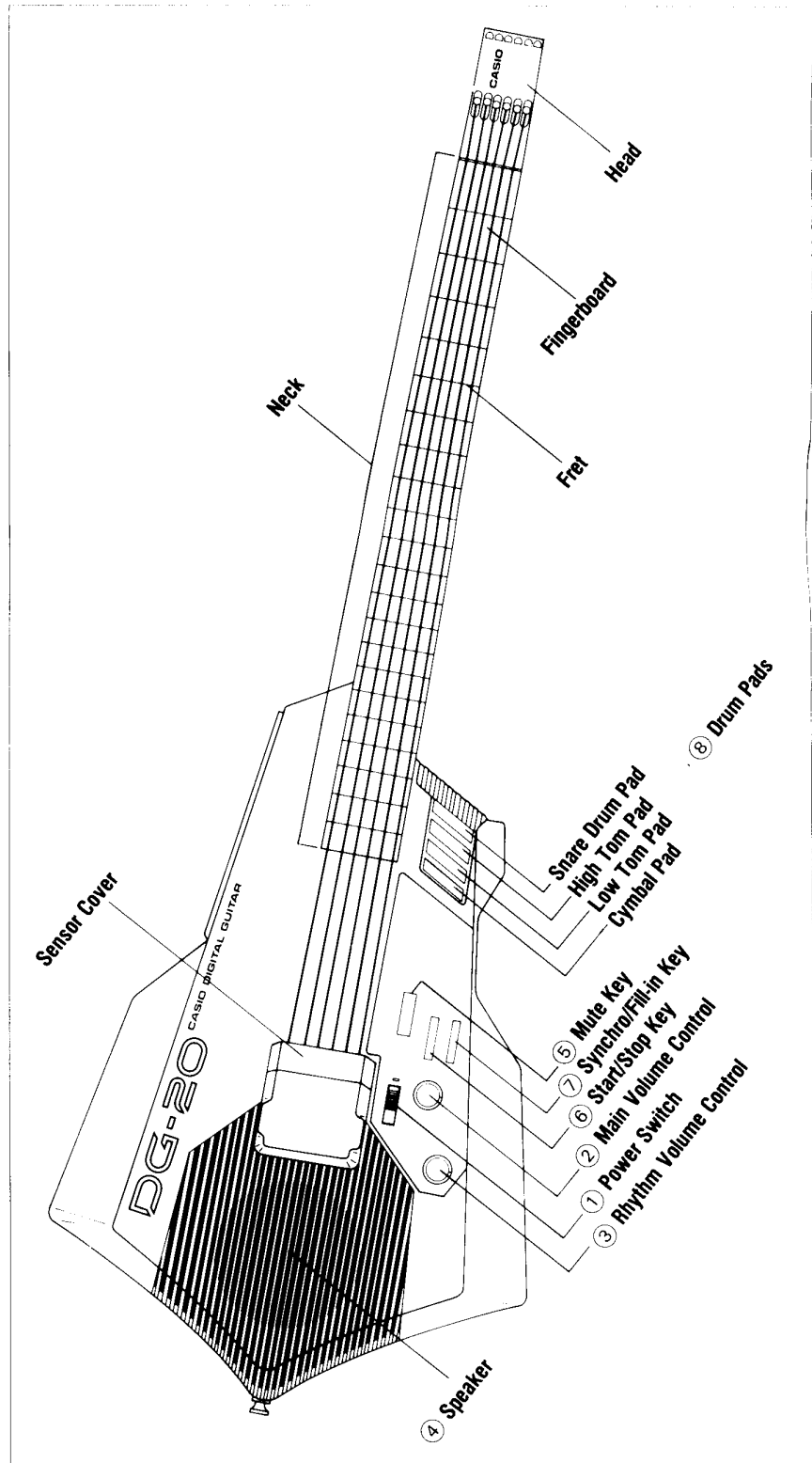

# Side Panel Control Section

**9 Tone Selectors,**  
**10 Select Key,**  
**11 Select Indicator**

The tone selectors are used to specify desired guitar tones. Note that two tones are assigned to each tone selector. When the select indicator is OFF, the upper tones are specified. To select a lower tone (written in green), press the select key. The select indicator lights indicating lower tones may be selected.

*Note that effects such as Chorus and Vibrato are built-in to various tones.*

**12 Rhythm Selectors,**  
**13 Select Key,**  
**14 Select Indicator**

The rhythm selectors are used to specify desired rhythms. Note that two rhythms are assigned to each rhythm selector. When the select indicator is OFF, the upper rhythms are specified. To select a lower rhythm (written in green), press the select key. The select indicator lights indicating lower rhythms may be selected.

**15 Tempo Control Keys**

Used to adjust rhythm tempo. Press the <▲> key to speed up rhythm, or the <▼> key to slow rhythm down. Hold the key down to make major changes in tempo. *Press both keys simultaneously to initialize tempo (reset at factory setting J = 120).*

**16 Tempo Indicator**

Indicates the tempo of auto-rhythm. Lights to indicate the first beat of each measure. Also lights when in stand-by status in Synchro start mode.

**17 Sustain/Reverb Selector** **18 Solo Selector**

When corresponding indicator is ON, sustain or reverb effect is added to selected Tone. When OFF, sustain or reverb effect is not added to selected Tone. Note that switch is in the ON mode immediately after power is turned ON.

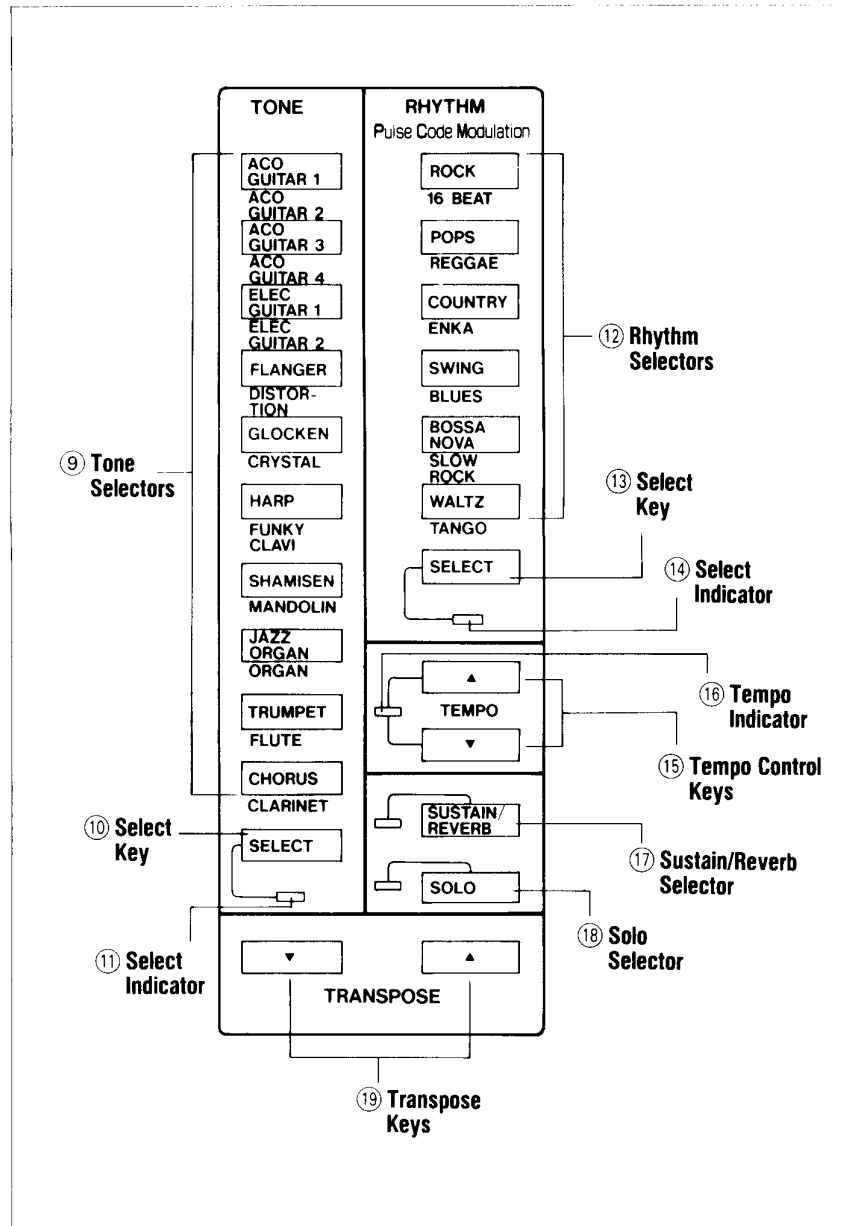

**19 Transpose Keys**

Used to raise or lower key in 11 half-step increments. Key is raised one half step each time the <▲> key is pressed, and lowered one half step each time the <▼> key is pressed.

*Note that pitch is set at A4 = 442Hz in initialized state (when power is turned ON).*

# Connections

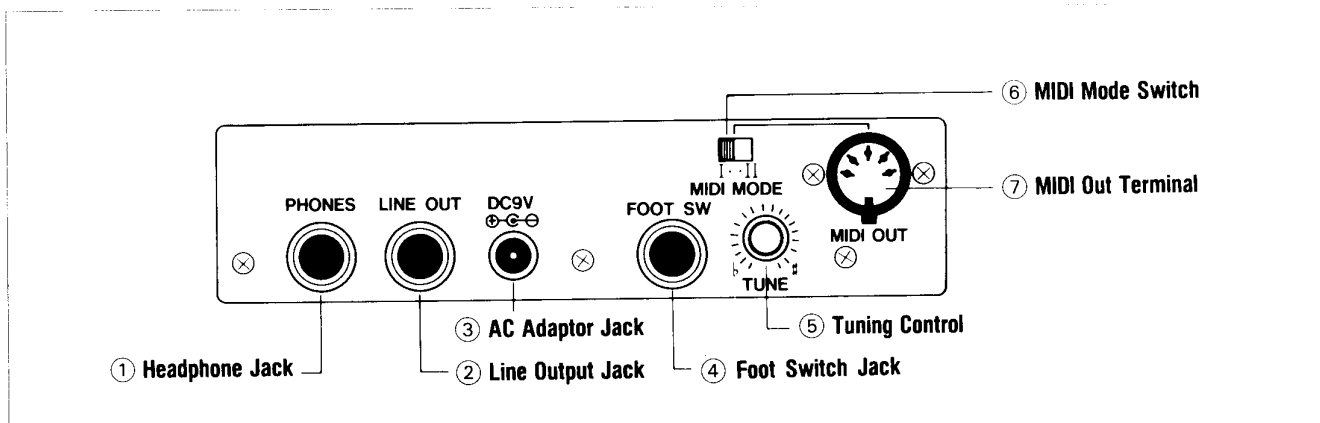

**1 Headphone Jack**

Connect headphones for private listening (useful at night).

**2 Line Output Jack**

Connect audio or musical instrument amplifiers.

**3 AC Adaptor Jack**

Input cord from AC adaptor (AD-5) when using home current or car adaptor (CA-5).

**4 Foot Switch Jack**

Connect optional foot switch (SP-2, SP-10, optional) for foot-pedal control of auto-rhythm ON/OFF.

**5 Tuning Control**

Used to control tuning, raising or lowering tuning within a  $\pm 50$  cents range. Useful in matching tuning with other instruments.

**6 MIDI Mode Switch**

Used to select either MIDI mode 3 (MODE I) or mode 4 (MODE II).

**7 MIDI Out Terminal**

Connect DG-20 to other MIDI instruments or devices. MIDI messages transmitted through this output. (Refer to page 8 for further information on MIDI).

## Making Music On the DG-20

1. When a string is played, the selected tone is triggered, and is output through the built-in speaker.

2. The digital guitar has switches built into the fingerboard behind each fret. These are used for pitch detection. If your finger(s) is not properly centered over the strings you depress, neighboring strings may sound (even though you haven't depressed neighboring strings), as the switches may be activated.

*No sound is output if strings are played too softly.*

## Note:

There are two different basic types of preset sounds built-in to the DG-20—sounds which decay, such as the acoustic guitar tone, and sounds which are sustained, such as the jazz organ tone. Sustained sounds may be cut off by using the mute key, or by releasing the fretboard (which turns OFF the built-in sensor switch).

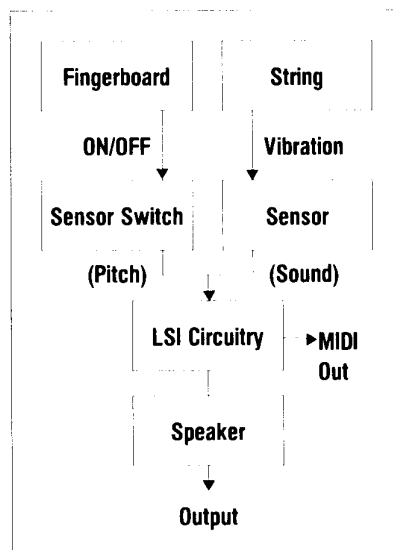

## Batteries

### Use Six D-size (SUM-1) Batteries

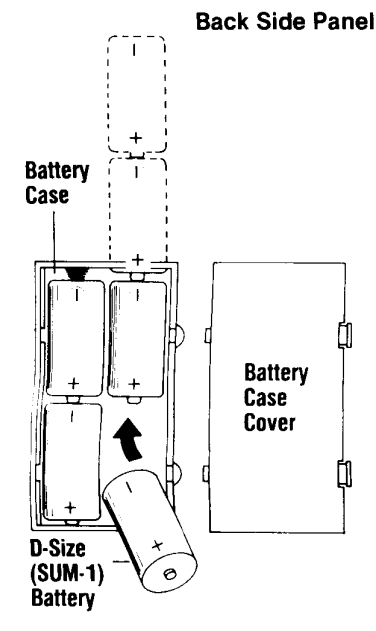

### Inserting and Replacing Batteries

Remove the battery compartment cover and insert batteries, taking care that polarity is correct. When replacing batteries, be sure to replace all six to ensure longer battery life.

*Turn power OFF before replacing batteries.*

- Battery life of high-performance SUM-1 dry cells is approximately 18 hours. Weakened batteries will cause the power indicator to lose its brightness and result in lower volume, poor tonal quality and eventually misoperation of functions. If such symptoms occur, replace all six batteries with new ones as soon as possible.

## Household AC Current

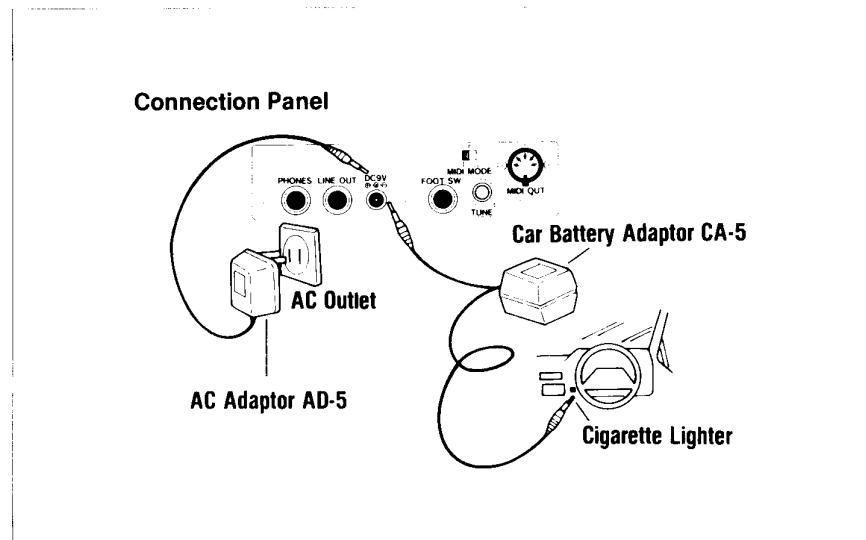

### Connecting AC Adaptor

Connection of an AC adaptor (AD-5, optional) allows the unit to be powered by standard household current.

Use only an adaptor with the same voltage rating as your local power supply.

## Car Cigarette Lighter

### Connecting Car Adaptor

Connection of a car adaptor (CA-5, optional) allows the unit to be powered through a vehicle's cigarette lighter socket.

- Always ensure that the power of the unit is OFF when connecting or disconnecting adaptors.
- Remove batteries from the battery compartment when the unit is not used for extended periods. Battery leakage can damage electrical components.
- Only use specified CASIO AC or Car adaptors to prevent damage to the unit.
- Adaptors normally become warm when connected to the power source. This is not cause for worry, but adaptors should be disconnected whenever the unit is not used for extended periods.

### Auto Power Off Function

An automatic power cut-off function activates approximately 6 minutes after the last operation of the unit. Power supply can be restored by switching the power of the unit OFF and then ON again.

# CHANGING STRINGS

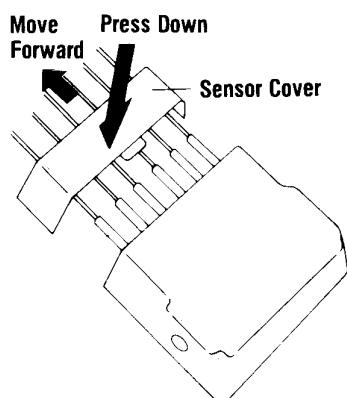

1. As shown in the above diagram, press down on the sensor cover and move it toward the neck. *Do not use excessive force on any parts in the sensor assembly.*

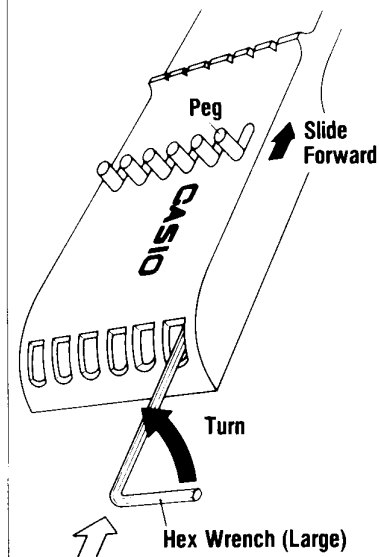

3. Insert the accessory hex wrench (large) into the head and turn it counter-clockwise to slide the headpiece towards the body. Next, insert the other hex wrench (small) in the headpiece and loosen the screw.

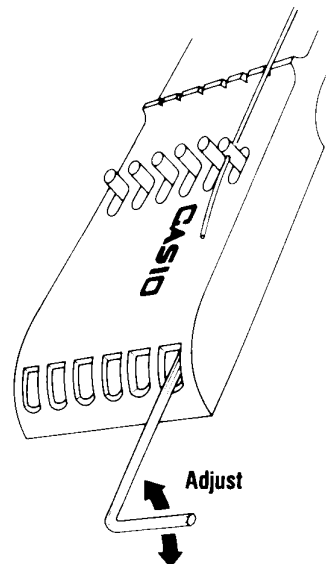

4. Next, pull the string through the hole in the headpiece and tighten the headpiece screw while pulling the string taut. Using the large hex wrench, move slide the headpiece back into position to adjust string tension. *Avoid tightening the strings excessively, as this may lead to neck warps or other damage. Also, do not use excessive force on the neck. Follow the same procedures to change all 6 strings.*

Pull String Through Notch and Hole

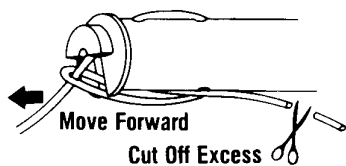
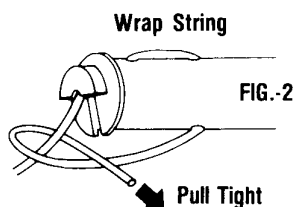
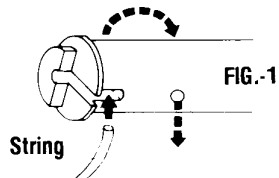

2. As shown in FIG-1 above, strings pass through a notch in the end of the sensor, and then through a hole in the sensor. After pulling through a few inches of string, tie the string as shown in FIG-2. Next, fix the string tight and cut off any excess.

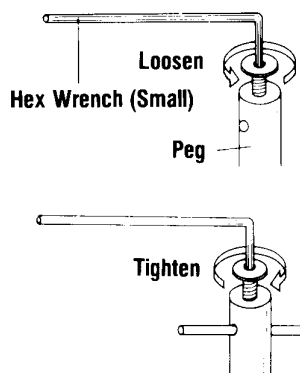

■ *Be sure to use nylon B string for all six strings. Never use steel strings or any other type strings.*

■ *Should the Allen wrench have been lost, apply to a musical instrument store or hardware store. The width across corners is 3mm at one end and 1.5mm at the other end.*

■ *When the guitar is stowed away for a long time, loosen all the strings.*



# About MIDI

## I. Performing Using MIDI

### Remote and Ensemble Performance

By connecting the DG-20 to another MIDI instrument, 6-note polyphonic note messages can be sent to the other instrument. Through this the DG-20 can be used to "control" or play the other instrument, for example a keyboard instrument.

### Sequential Performance with Rhythm Machines and Sequencers

The DG-20 can be used to start/stop the connected drum machines or sequencers, for precision rhythm track or sequence control.

### Control Up To 6 Different Sound Sources (MIDI Mode 4)

By connecting the DG-20 to a CZ-1, CZ-5000 or other keyboard with a multi-receive mode, or by connecting the DG-20 to up to 6 different keyboards, a maximum of 6 different voices can be controlled by the DG-20—with a different voice assigned to each string.

## II. Transmitted MIDI Data

### The DG-20 Can Transmit The Following MIDI Data

- 1) Pitch, ON/OFF
- 2) Start/stop
- 3) Timing clock
- 4) Program change (voice number, rhythm number)
- 5) Portamento (When changed from MODE I to MODE II, PORTAMENTO ON is sent automatically to Channels 1 through 6. When you switch from MODE I to MODE II, PORTAMENTO OFF is sent on the Basic Channel only).

## III. Functions of MIDI Terminal and MIDI Mode Switch

### MIDI Out Terminal

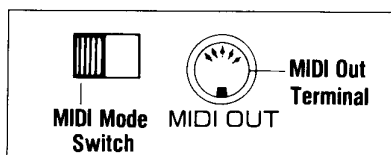

This terminal is used to send MIDI messages from the DG-20 to external MIDI instruments and devices. It is connected to the MIDI IN terminal of other MIDI instruments.

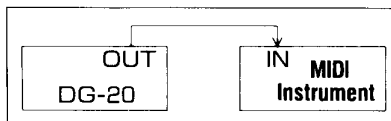

### MIDI Mode Switch

This switch is used to specify the MIDI performance modes, as shown below;  
 MIDI Mode I: Poly mode (Mode 3)  
 MIDI Mode II: Mono mode (Mode 4)

#### a. MIDI Mode I: Poly mode (Mode 3)

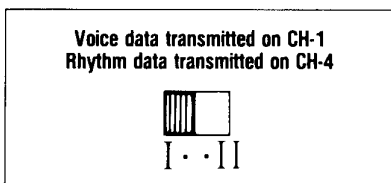

#### b. MIDI MODE II: Mono mode (Mode 4)

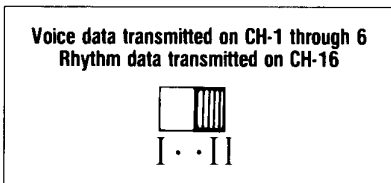

## Examples of MIDI Connections

### a. Example of MIDI Mode I application:

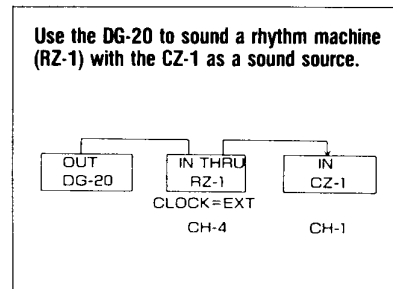

### b. Example of MIDI Mode II application:

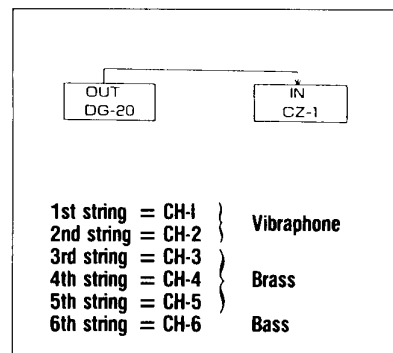

In the above application, the vibraphone tone can be sounded by a playing strings 1 and 2, with Brass tones on strings 3 through 5, and a bass tone sounded on string 6.

# SPECIFICATIONS

**Model:**

Casio Digital Guitar DG-20

**Polyphonic:**

6-note polyphonic (mono in solo mode)

**Preset Tones:**

20 tones; acoustic guitar 1 ~ 4, electric guitar 1 and 2, flanger, glocken, harp, shamisen, jazz organ, trumpet, chorus, distortion, crystal, funky clavi, mandolin, organ, flute, clarinet

**Effects:**

sustain/reverb, vibrato (built-in to tones)

**Auto-rhythms:**

12 Rhythms (PCM source); rock, 16 beat, pops, reggae, country, enka, swing, blues, bossanova, slow rock, waltz, tango

**Drum pads:**

4 onboard drum pads (snare drum, high tom, low tom, cymbal)

**Rhythm Controls:**

start/stop keys, synchro/fill-in key, tempo control keys, tempo indicator, rhythm volume control

**Other Controls:**

transpose (C-B in half-tone increments), mute, solo selector

**Tuning control:**

A4 = 442Hz  $\pm$  50 cents ( $\pm$  1/4 tone)

**Speaker:**

12cm (4 3/4 inch) dia.  $\times$  1 (2.0W)

**Terminals:**

headphone jack (output impedance = 3k  $\Omega$ , output voltage = 0.5 V (RMS) MAX), foot switch jack, MIDI OUT terminal, AC adaptor jack (DC 9V)

**Power Source:**

3-way AC/DC power source;  
DC: 6 D-size dry cell batteries  
(Battery Life approx. 18 hours)  
AC: AC adaptor (AD-5, optional)  
Car Battery: car adaptor (CA-5, optional)

**Auto Power OFF:**

Power turns OFF automatically approximately 6 minutes after last use.

**Power Consumption:**

4.3W

**Dimensions:**

995(L)  $\times$  340(W)  $\times$  95(H) mm  
(39 3/16" (L)  $\times$  13 3/8" (W)  $\times$  3 3/4" (H))

**Weight:**

3.5kg (7.7 lbs) including batteries

**Standard Accessories:**

6 D-size dry cell batteries, 2 hex wrenches

**Optional Accessories:**

■ AC adaptor (AD-5) ■ Car adaptor (CA-5) ■ Custom soft case (SC-70G) ■ Headphones (CP-2) ■ Sustain pedal (SP-2, SP-10)

*All optional accessories are available through your authorized CASIO dealer.*

*Design and specifications subject to change without notice.*

<u>Symptom</u>	<u>Possible Cause</u>	<u>Remedy</u>
No sound is output, even when strings are played.	<ul style="list-style-type: none"> <li>■ Main volume control is at its minimum.</li> <li>■ Headphones connected.</li> <li>■ Auto power OFF function has turned power OFF.</li> </ul>	<ul style="list-style-type: none"> <li>■ Adjust main volume to desired level.</li> <li>■ Disconnect headphones.</li> <li>■ Turn power back ON (see page 6)</li> </ul>
Rhythm does not sound.	<ul style="list-style-type: none"> <li>■ Rhythm volume control is at its minimum.</li> </ul>	<ul style="list-style-type: none"> <li>■ Adjust rhythm volume to desired level.</li> </ul>
Sound is occasionally distorted.	<ul style="list-style-type: none"> <li>■ Interference caused by electrical appliances.</li> </ul>	<ul style="list-style-type: none"> <li>■ Use a power outlet away from appliances.</li> </ul>
Occasional reception of television or radio waves.	<ul style="list-style-type: none"> <li>■ High-output broadcasting station in neighborhood.</li> </ul>	<ul style="list-style-type: none"> <li>■ Try changing position of instrument.</li> <li>(Ex) If you're playing near a window, try moving away from window.</li> <li><i>For further suggestions, contact your service center.</i></li> </ul>
No sound output when unit is connected to external amp.	<ul style="list-style-type: none"> <li>■ Main volume control is at its minimum.</li> <li>■ Short in connection cord.</li> </ul>	<ul style="list-style-type: none"> <li>■ Raise main volume level.</li> <li>■ Replace connection cord.</li> </ul>

## Guidelines

### Laid Down by FCC Rules for Use of the Unit in the U.S.A.

#### Not Applicable to Other Areas.

This equipment generates and uses radio frequency energy and if not installed and used properly, that is, in strict accordance with the manufacturer's instructions, may cause interference to radio and television reception. It has been type tested and found to comply with the limits for a Class B computing device in accordance with the specifications in Subpart J of Part 15 of FCC Rules, which are designed to provide reasonable protection against such interference in a residential installation.

However, there is no guarantee that interference will not occur in a particular installation. If this equipment does cause interference to radio or television reception, which can be determined by turning the equipment off and on, the user is encouraged to try to correct the interference by one or more of the following measures:

- reorient the receiving antenna
- relocate the computer with respect to the receiver
- move the computer away from the receiver
- plug the computer into a different outlet so that computer and receiver are on different branch circuits.

If necessary, the user should consult the dealer or an experienced radio/television technician for additional suggestions. The user may find the following booklet prepared by the Federal Communications Commission helpful: "How to Identify and Resolve Radio-TV Interference Problems". This booklet is available from the US Government Printing Office, Washington, D.C., 20402, Stock No. 004-000-00345-4.